

# Figaro CO2 Sensor Module

## Features:

- \* **Small size**
- \* **Low power**
- \* **High accuracy**
- \* **Absolute measurement via dual sensors**

## Applications:

- \* **Indoor air quality control**
- \* **Fresh air ventilators**
- \* **Air conditioners**
- \* **Automatic fans and window openers**

The Figaro **FG-030** CO<sub>2</sub> module uses a compact NDIR (non-dispersive infrared) CO<sub>2</sub> sensor which has excellent performance characteristics, including high accuracy and low power consumption. Two detector elements inside the module make absolute measurement possible.

Every module is individually calibrated and is provided with both a UART and I2C digital interface. The FG-030 module is designed for simple integration into a user's products. It can be used in a wide range of applications such as ventilation controls for the improvement of energy savings and to assure a good indoor climate.

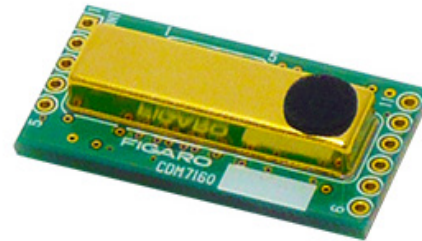

## Dimensions

Pin connection

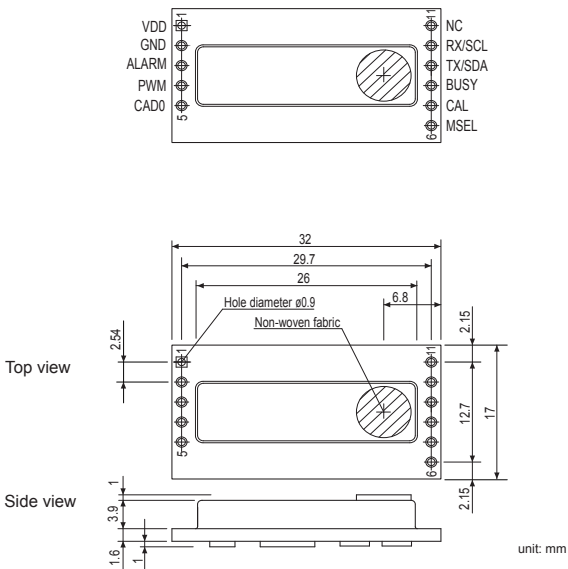

## Pin Connections

Pin No	Name	Description
1	VDD	Input voltage
2	GND	Common ground
3	ALARM	Alarm output
4	PWM	PWM output
5	CAD0	I2C slave address selection input (internal pull up)
6	MSEL	Communication mode signal input I2C/UART (internal pull up)
7	CAL	Air/zero adjustment input (internal pull up)
8	BUSY	BUSY signal output
9	Tx/SDA	UART Tx output/ I2C SDA input/output
10	Rx/SCL	UART Rx input/ I2C SCL input
11	NC	not connected

## Specifications

Product name	Carbon dioxide (CO <sub>2</sub> ) sensor module
Model No.	FG-030
Detection range	300~5,000ppm CO <sub>2</sub>
Operating principle	Non-dispersive infrared (NDIR)
Power supply	4.75~5.25V DC
Current consumption	60mA peak, 10mA avg.
Accuracy (NOTE 2)	±(50ppm+3% of reading) in the range of 300~5,000ppm CO <sub>2</sub>
Pressure dependency	approx 1% of reading / kPa
Response time (T90)	2 min. (diffusion)
Operating conditions	0~50°C/0~85%RH (no condensation)
Storage conditions	-30~70°C/0~85%RH (no condensation)
Communication port	UART/ I2C (gas conc. output 0~10,000ppm)
Measurement interval	2 sec.
PWM output (1kHz)	0~100% duty cycle for 0~5,000ppm, CMOS output
Alarm output	CMOS output: High > 1,000ppm Low < 900ppm
Dimensions	32 x 17 x 7.5 (mm)
Weight	approx. 3g

**NOTE 1:** FG-030 is an ESD-sensitive product. No ESD protection components such as zener diodes or varistors are used in this product. It is recommended that ESD protection equipment be used for handling the module during assembly of application products. It is also recommended that ESD protection components and/or an ESD protection enclosure should be used as required for the intended application when this product is embedded into inished products.

**NOTE 2:** Represents accuracy at the time of factory test. For long term accuracy, please refer to "Fig.5-Long term stability" as shown in *Technical Information for FG-030*.

**IMPORTANT:** This product is designed for use in indoor air quality control systems, including variable air volume systems and demand controlled ventilation systems. Please consult Figaro prior to use of this product in other applications. This product is ***not*** designed and authorized for use as a critical component in life support applications wherein a failure or malfunction of the products may result in injury or threat to life.