

SprintIR^{6S} 5% to 100% CO2 Sensor

Ultra-fast response Carbon Dioxide Sensor

The SprintIR6S is a high speed CO2 sensor that can take up to 20 readings per second, Response rate is enhanced by using a measuring cell 1/6 the volume of the standard SPRINTIR, which allows for lower flow rates / differential pressure to attain the same response. This makes it useful for low volume or pressure sensitive measurements.

Combined with the MX board, it is suitable for applications where capture of rapidly changing CO2 concentrations combined with %RH/Temp. compensation is required.

FEATURES

- Ultra-fast response rate - 6X faster than the SprintIR
- %RH and Temperature compensation on MX Board
- High speed sensing - 20 readings per second (20Hz)
- Low power - 35mW

AVAILABLE MODELS

Development Kit – Easy to use, simply plug the MX Board into your PC via USB. Use our free GasLab[®] software to measure and graph carbon dioxide, barometric pressure, temperature, and % relative humidity. Includes on-board memory for data logging.

MX Board – Same functionality as the development kit without USB cable or software.

Sensor Only – for integration into high-volume OEM products.

SPECIFICATIONS

- CO2 Sensing Method: Non-dispersive infrared (NDIR) absorption with patented gold-plated optics and solid-state source and detector
- Sample Method: Flow through
- Measurement Range: 0-5%, 0-20%, 0-100%
- Accuracy: ± 70 ppm +/- 5% of reading²
- Accuracy @ 100% Range: ± 300 ppm +/-5% of reading²
- Non Linearity: < 1% of FS
- Pressure Dependence 0.13% of reading per mm Hg in normal atmospheric conditions.
- Operating Pressure Range: Atmospheric pressure range. Lower and higher pressures require more advanced pressure compensation.
- Response Time: Flow Rate Dependent – see graph below. Response time also depends on user configurable digital filter settings.
- Warm-up Time: < 30 seconds
- Operating Conditions: 0°C to 50°C, 0 to 95% RH, non-condensing
- Recommended Storage: -30°C to +70°C
- Dimensions: 25mm x 40mm x 31mm on PCB (LxWxH)
- Weight: 16g sensor, 5.8g board



Part Nos.

100% CO2

CM-40801: MX DevKit
CM-40800: MX Board + Sensor
GC-0030: Sensor Only

20% CO2

CM-40401: MX DevKit
CM-40400: MX Board + Sensor
GC-0029: Sensor Only

5% CO2

CM-40301: MX DevKit
CM-40300: MX Board + Sensor
GC-0028: Sensor Only

Electrical/ Mechanical	
Power Input	3.25 to 5.5V. (3.3V recommended) Peak Current 33mA ³ Average Current <12mA ³
Power Consumption	35 mW ³
Dimensions and Wiring Connections	

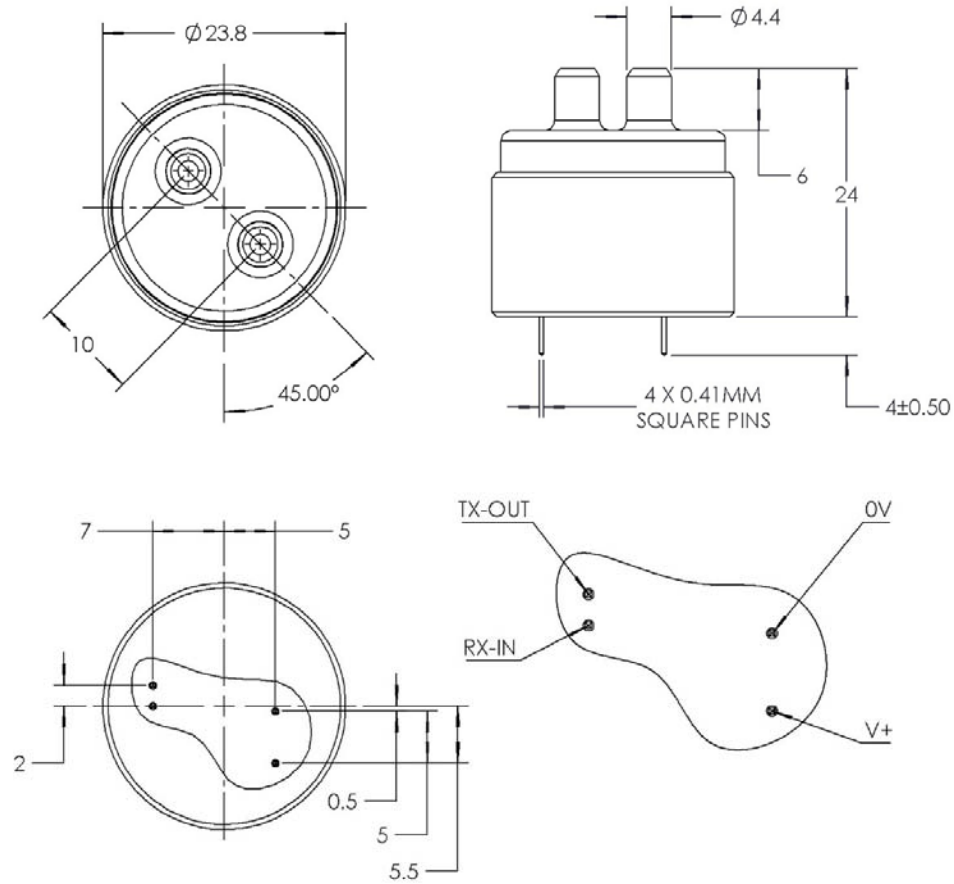

Pin	Comments
0V	GND
V+	3V3 to 5V
RX-IN	Sensor Rx. 5V tolerant
TX-OUT	Sensor Tx. $V_{oh} = 3V$

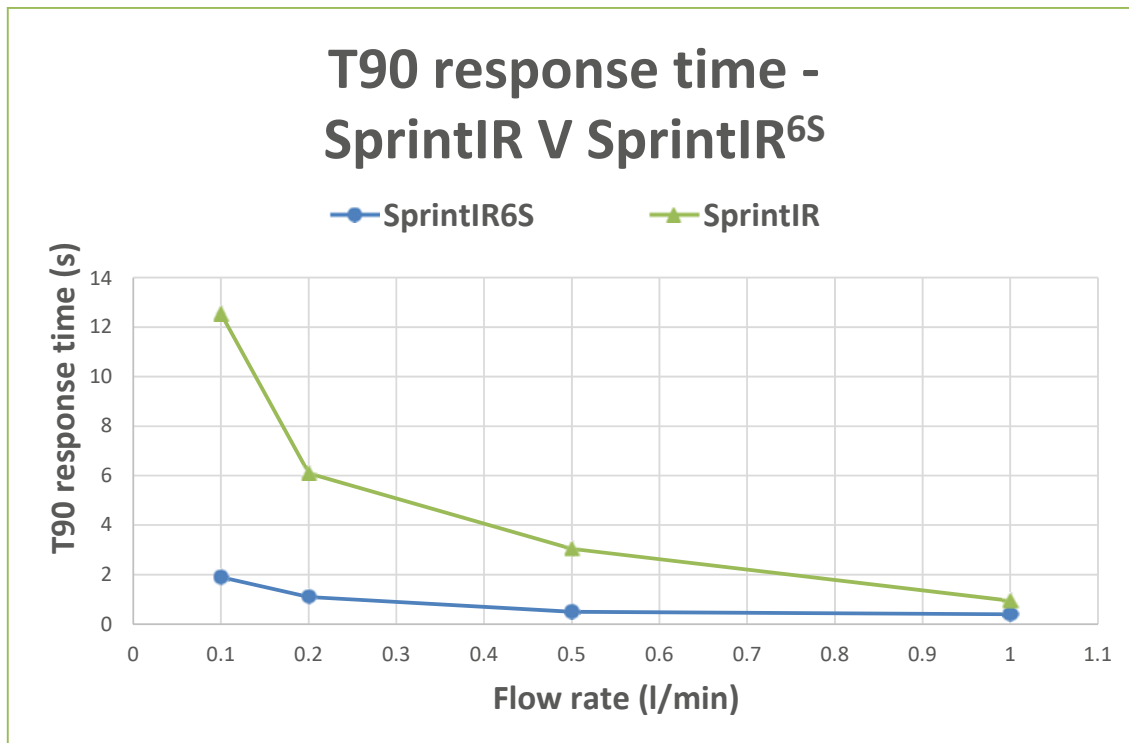

T90 time measured from 0 to 10% CO₂. Digital filter switched off.

Note 1: Based on 0.1 litres per minute flow rate and 0-10% step change in CO₂ concentration.

Note 2: All measurements are at STP unless otherwise stated.

Note 3: Power measurements for standard CO₂ sensor with 20 readings per second.

This documentation is provided on an as-is basis and no warranty as to its suitability or accuracy for any particular purpose is either made or implied. Gas Sensing Solutions Ltd will not accept any claim for damages howsoever arising as a result of use or failure of this information. Your statutory rights are not affected. This information is not intended for use in any medical appliance, device or system in which the failure of the product might reasonably be expected to result in personal injury. This document provides preliminary information that may be subject to change without notice.