

Installation Manual

a**SENSE**

Dismounting of the sensor

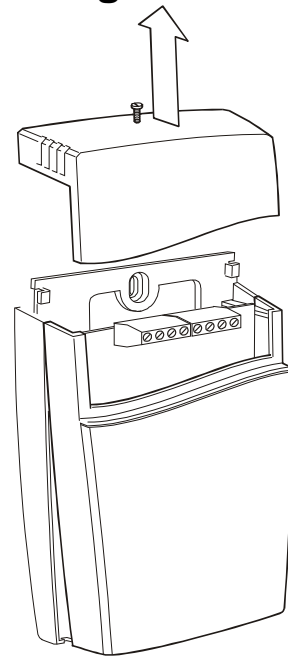
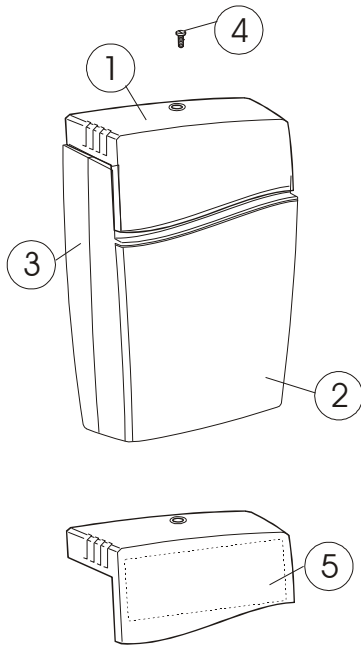

Pull the top part upwards

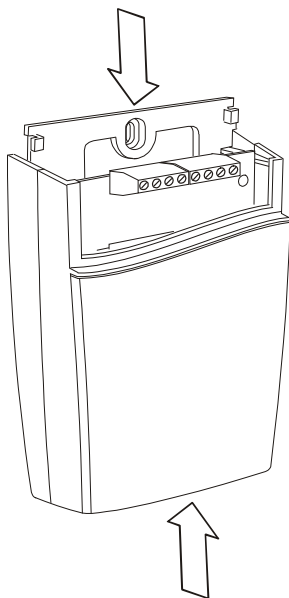

Push the front part upwards while keeping the wall plate steady

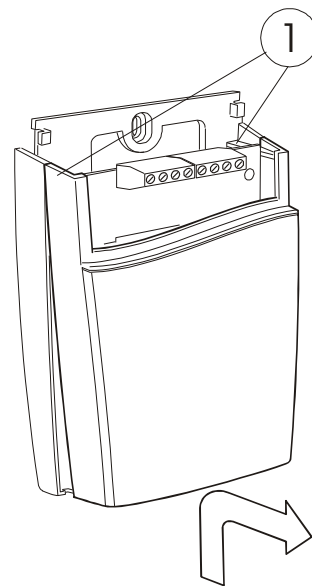

Fold the front part forwards and loose it from the hooks (#1)

Mounting of the sensor

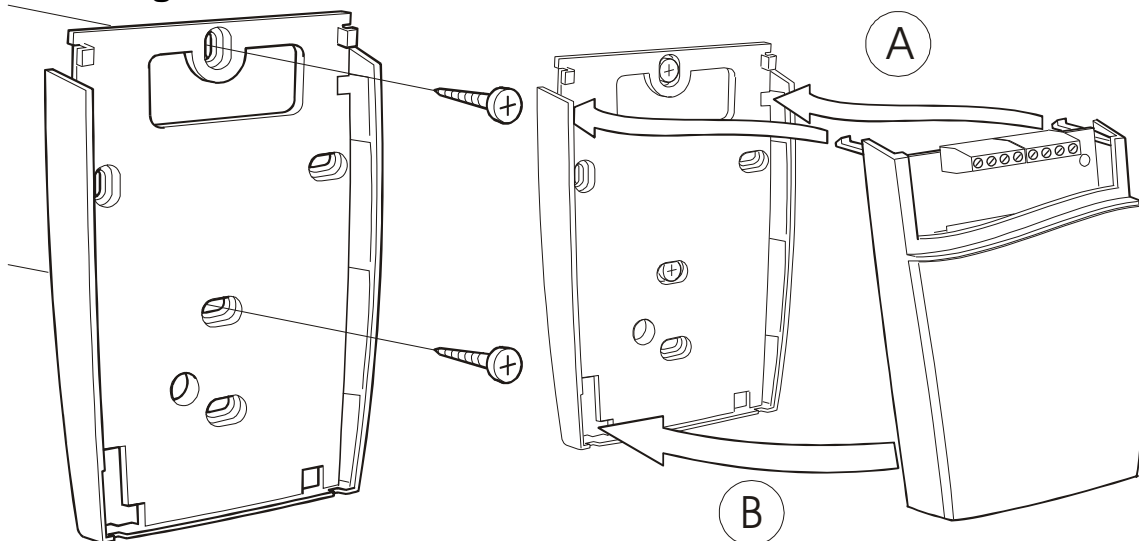

The wall plate is screwed onto the wall

(A) Put the top tabs of the front part into the top holes of the wall plate.

(B) Press the lower edge of the case onto the wall plate to latch

If the connection cables are drawn through a conduit the conduit must be sealed.

Air of different temperature may otherwise disturb the temperature measurements.

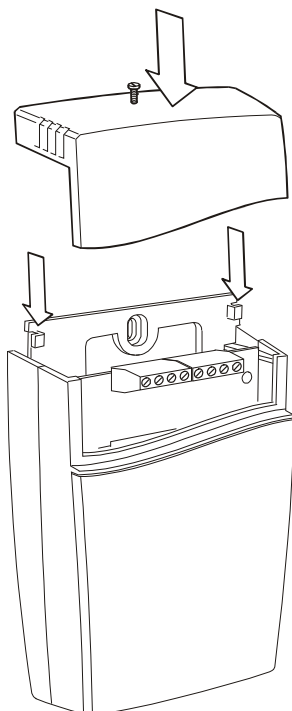

The top part is pushed under the locking hooks of the wall plate and is secured with a screw

The screw head diameter should be **max 7,5 mm**

The screw head height should be **max 2,5 mm**

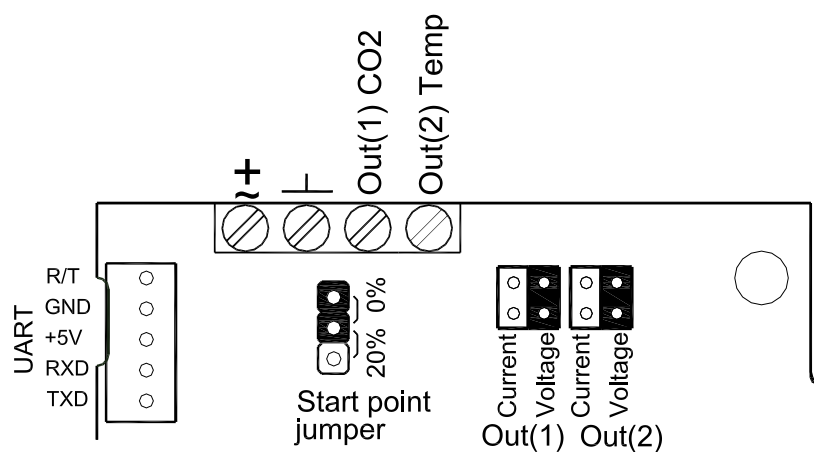

Terminals and jumpers on aSENSE.

The darker positions are default settings.

Terminals and jumpers are located under the top part.



If for some reason the PCB must be removed it must be handled carefully and protected from electrostatic discharge! Normally, removing the PCB is not required.

Electrical connections

The power supply has to be connected to \sim and \perp . \perp is considered as system ground. If the analogue output is connected to a controller *the same ground reference has to be used for the aSENSE unit and for the control system!* Unless different transformers are used, special precautions need to be taken.

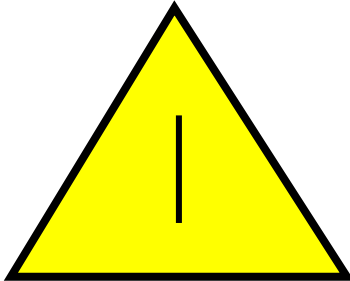

PLEASE NOTE!

The same ground reference has to be used for the aSENSE unit and for the control system!

If possible keep the sensor powered up after mounting. Connect the analogue output before measuring.

Connection Terminal	Function	Electrical Data	Remarks
\sim \perp	Power (+)	24 VAC/DC+ (+-20%), 1W	See note 1
	Power ground (-)	24 VAC/DC-	
Out(1) CO ₂	Analogue Output 1 (+) Standard 0-2000ppm See label for non-standard	0-10 VDC or 0-20 mA 2-10 VDC or 0-20 mA or See label	According to positions of Out(1) and start point jumpers. See note 1!
Out(2) Temp	Analogue Output 2 (+) Standard temperature 0-50 °C or 32-122 °F See label for non-standard	Same as Output 1	According to positions of Out(2) and start point jumpers. See note 1 and 2!

Note 1: The ground terminal is used as negative power supply DC input or AC phase ground \perp (halfwave rectifier). A single transformer may be used for the entire system.

Note 2: aSENSE can deliver a voltage or a current loop for Out(1) / Out(2). To change between voltage and current output mode the hardware jumpers are used. There is one jumper for Out(1) and one for Out(2), so that one output can be a voltage output and the other a current output. Both, voltage output and current output can have start points 0 % (0-10 VDC or 0-20mA) or 20% (2-10 VDC or 4-20mA). The same start point is used for both outputs. See the user manual.

Dimensions and holes

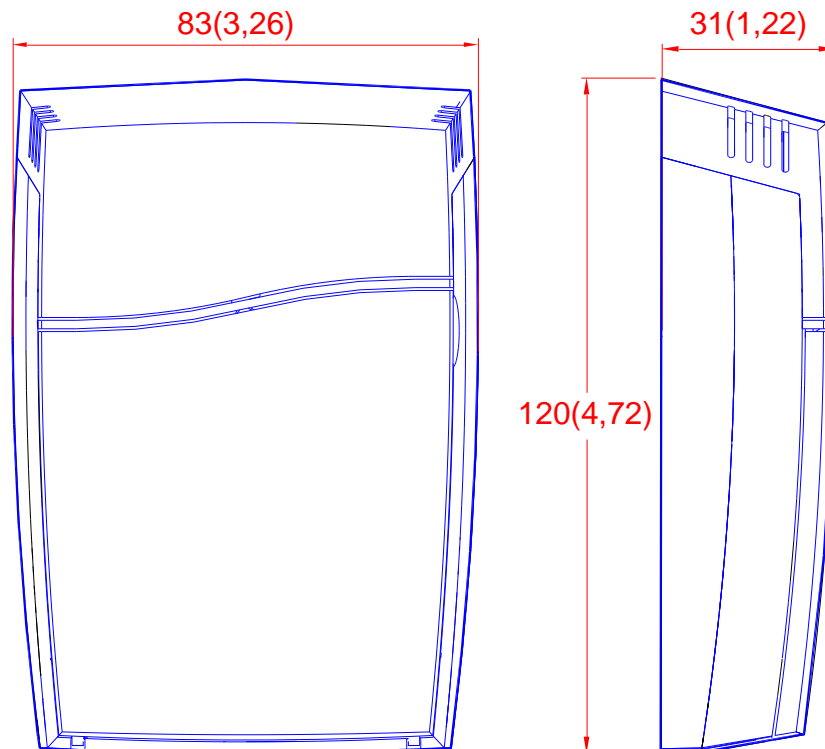

Dimensions of sensor in mm and (inches)

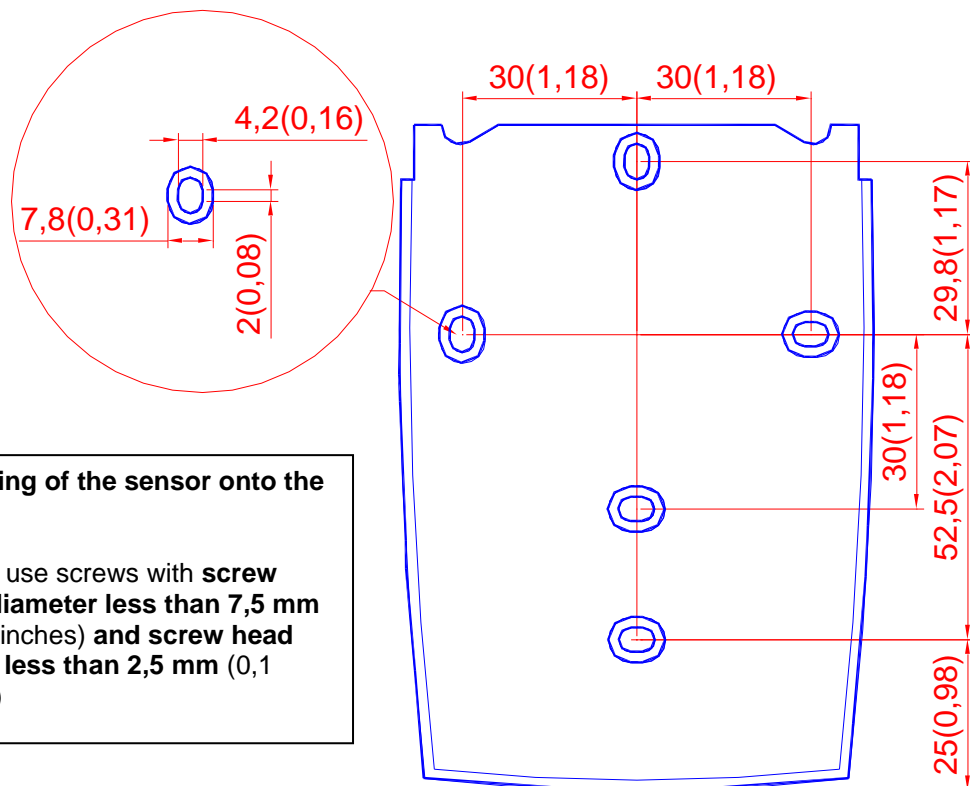

Mounting of the sensor onto the wall

Please use screws with **screw head diameter less than 7,5 mm** (0,295 inches) and **screw head height less than 2,5 mm** (0,1 inches)

Dimensions of mounting plate in mm and (inches)